

The World's Most Trusted Industrial Bolting Systems

# jGun™ Dual Speed Plus

The Speed and Convenience of an Impact Wrench without the Noise, Vibration and Inaccuracy

## Features:

- Calibrated torque output up to 8,000 ft-lbs
- Quick switch from fast rundown to accurate torque
- Fixtures available for all challenging applications
- Built to withstand heavy use in all industries
- Industry leading power-to-weight ratio



**COMPATIBLE WITH THE HYTORC WASHER FOR ADDED SAFETY, SPEED, AND ACCURACY**



AVAILABLE WITH SAFETY LEVER

This patented safety mechanism drastically reduces the risk of operator injury. The lever must be depressed while pulling the trigger, ensuring that hands are clear from pinch points.



**24 HOUR SERVICE**

**888-GUN-2-GUN**

**[www.torquegun.com](http://www.torquegun.com)**

**TORQUE GUN**

A HYTORC COMPANY

120 WESLEY ST., S. HACKENSACK, NJ 07606

## ACCESSORIES



**HYTORC WASHER**

Replace your standard washer with the revolutionary HYTORC Washer to optimize your bolted joint. This simple upgrade is the best value in the industry for increased safety, speed and accuracy on bolting jobs.



**FRL UNIT**

Filter, Regulator and Lubrication Unit. For use with all torque guns. Optional Silencer Unit to reduce operational noise by 35%, down to a very low 70-75 Db. Ideal for indoor operation or repetitive maintenance.



**OFFSET LINKS**

For tight spaces and limited overhead clearance, the offset link is the answer. This slim-design link works with our full line of pneumatic and hydraulic tools and is available with various sized hex cartridges to fit on all applications.

## DIMENSIONAL DATA

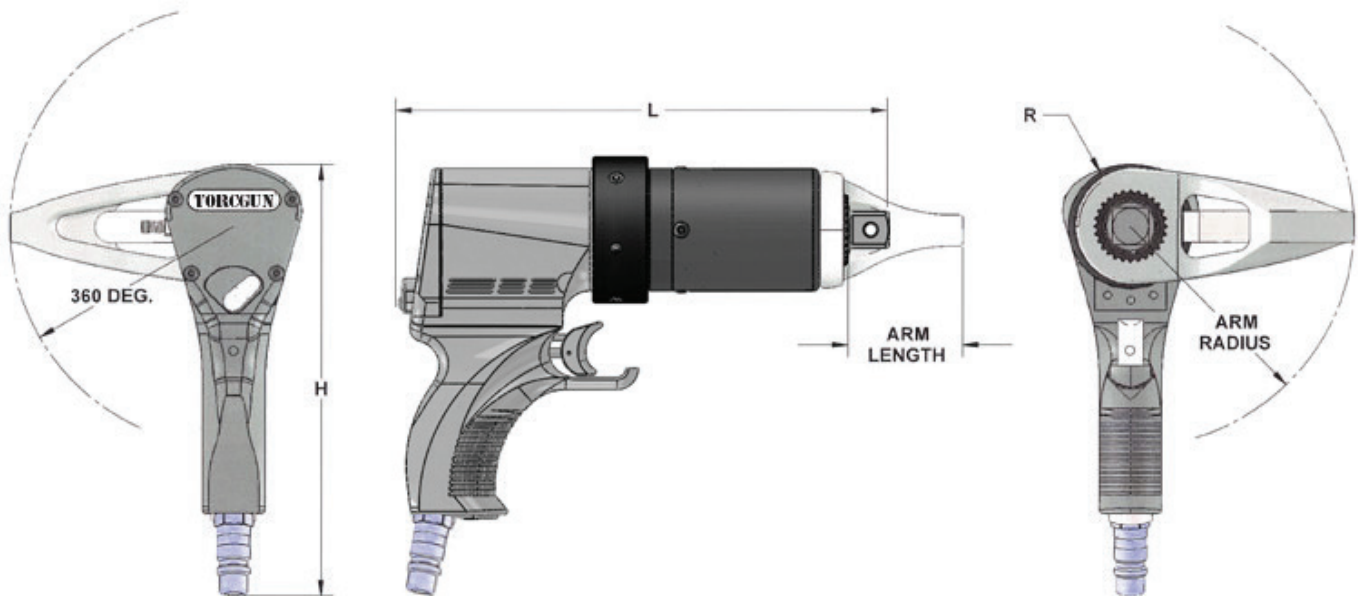

	Torque Range	Drive	Bolt Sizes	H	L	R	Rundown RPM	Final Torque RPM	Weight w/o Arm	Weight w/ Arm
Model	Ft. Lbs./Nm			Inches/cm					Lbs./Kg	
<b>J-A-5-AP</b>	80-385/109-521	3/4"	1/2" to 1"	7.40/18.80	10.03/25.47	1.25/3.18	420	24	9.04/4.10	10.25/4.6
<b>J-A1-AP</b>	315-1225/428-1660	3/4"	7/8" to 1 3/8"	8.92/22.66	10.76/27.33	1.25/3.18	120	6.5	9.7/4.40	10.9/4.9
<b>J-A2-AP</b>	500-2025/678-2050	1"	1" to 1 5/8"	8.42/21.4	12.5/31.8	1.25/3.2	90	5	15/6.8	18.25/8.27
<b>J-A3-AP</b>	785-3250/1065-4406	1"	1 1/4" to 1 7/8"	7.50/19.05	12.48/31.70	3.19/8.10	35	2	12.0/5.4	15.35/7.0
<b>J-A5-AP</b>	1175-5200/1593-7050	1 1/2"	1 13/16" to 3 1/8"	8.42/21.39	14.65/37.21	4.48/11.38	38	2.5	22.5/10.2	28.75/13.4
<b>J-A8-AP</b>	1600-8300/2170-11253	1 1/2"	1 13/16" to 3 1/8"	8.46/21.49	15.38/39.10	4.56/11.58	35	1.5	28/12.7	36.5/16.6