

The World's Most Trusted Industrial Bolting Systems

HY-AIR PNEUMATIC PUMP

MAIN FEATURES

- Protective Caging
- Light weight
- 3-Stage
- 4-Tool Adapter
- Gauge psi/bar FS 1.0%
- Remote control air – 5m length

OPTIONS

- Calibrated Gauge with Certificate
- 10m / 30ft Remote Control Cable
- Semi-Automatic (-A)
- Two gallon reservoir

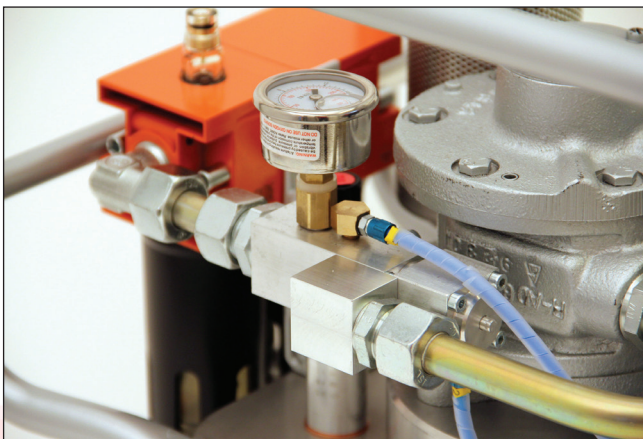
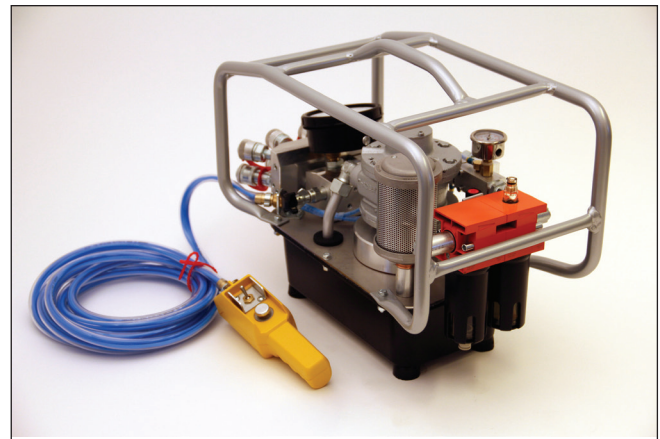
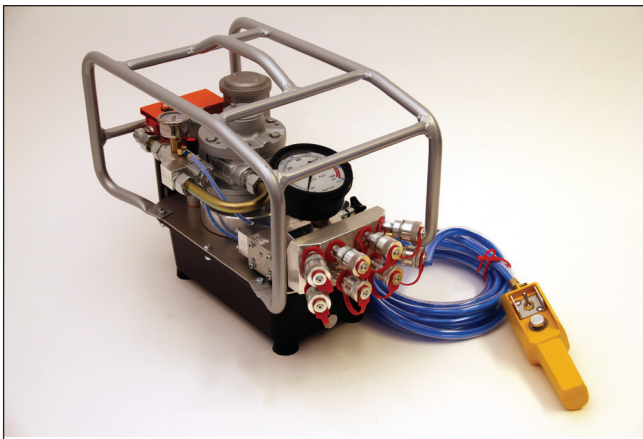

24 Hour SERVICE

800-FOR-HYTORC

www.hytorc.com

HYTORC®
Since 1968

333 RT. 17 N., MAHWAH, NJ 07430

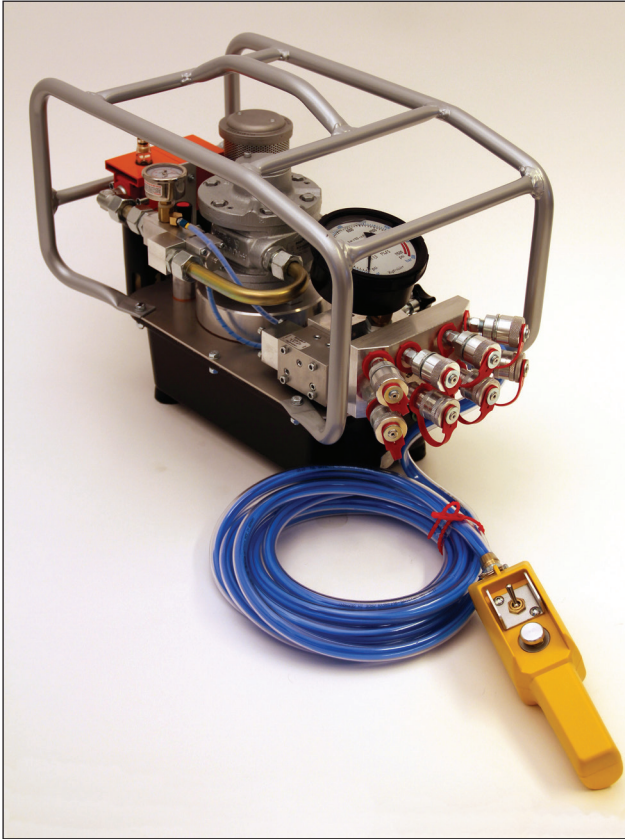

*This Pump with our tools can be ATEX Certified

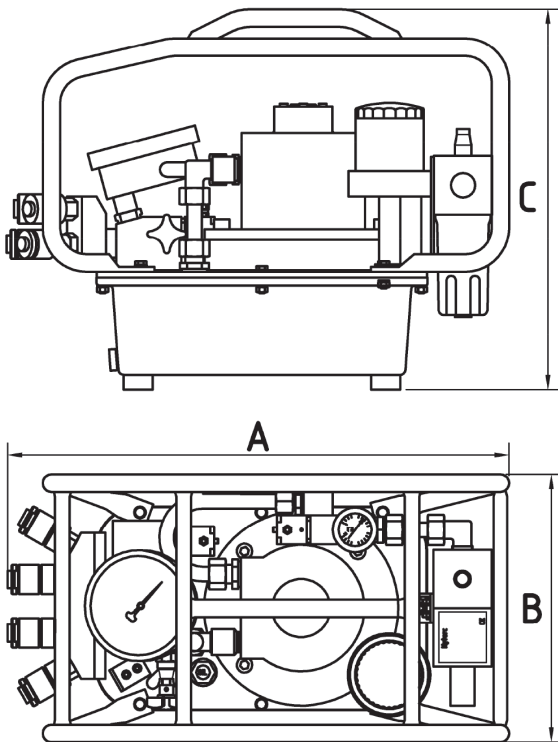

AIR CONSUMPTION:

400 – 1000 kPa / 60 l/sec.

(4 – 10 bar)

55 – 150 psi / 3800 cu.in/sec.

DIMENSIONS:

A = 20.4" (520 mm)

B = 10.9" (275 mm)

C = 15.5" (395 mm)

WEIGHT:

46.3 lbs (21 kg) – without oil

OIL FLOW:

Max. oil flow: 770 cu.in/min (12,5 l/min.)
up to 1 000 psi (bis 70 bar)

Middle pressure oil flow: 135 cu.in/min (2,2 l/min.)
up to 4 200 psi (bis 300 bar)

High pressure oil flow: 66 cu.in/min (1,0 l/min.)
up to 10.000 psi (bis 700 bar)